

Higharc, Inc. is not an architectural firm nor are the artistic representations contained herein intended to be construed as ready-to-use architectural plans, construction documents, drawings, renderings, or any other similar or related documents. All drawings are artist's representations only and solely intended to reflect design intent derived exclusively from the home building plans and associated information, data, and specifications provided by EPCON OH - FDG. Higharc, Inc. is not responsible, nor may it be held liable for any errors or omissions contained herein or resulting from its usage. Any usage of the representations should be reviewed by local professionals to ensure conformance with local and state codes and be field verified prior to the start of any construction.

ALL RIGHTS ARE RESERVED IN THIS INFORMATION AND ALL RELATED ILLUSTRATIONS, PLANS, BLUEPRINTS, SKETCHES, DRAWINGS OR OTHER TANGIBLE EXPRESSIONS THEREOF, WHICH ARE THE PROPERTY OF EPCON COMMUNITIES FRANCHISING, INC. 500 STONEHEDGE PARKWAY, DUBLIN, OH, 43017, TELEPHONE 614.652.3527. NO ONE MAY BUILD, LICENSE, TRANSFER, REPRODUCE OR DUPLICATE THIS WORK IN ANY WAY WITHOUT THE WRITTEN AUTHORIZATION OF EPCON COMMUNITIES FRANCHISING, INC. THESE DRAWINGS SHALL BE USED IN CONFORMANCE WITH ALL LOCAL BUILDING, MECHANICAL, PLUMBING AND ELECTRICAL CODES AND SHALL MEET THE REQUIREMENTS OF THE HEALTH DEPARTMENT, FIRE MARSHALL, AMERICANS WITH DISABILITIES ACT, ACCESSIBILITY GUIDELINES (ADAAG), THE FAIR HOUSING ACT ACCESSIBILITY GUIDELINES (FHAAG), AND SHALL BE CONSTRUCTED IN CONFORMANCE WITH STATE AND LOCAL ENERGY REQUIREMENTS.

ISSUE	DESCRIPTION	DATE
01	BUILDER SET	6/14/2022

REV	DATE
1	09 / 15 / 2022



5190 BRADEN LANE - LOT 59

MASTER PLAN: Promenade Plus | ELEVATION: Elevation B | COMMUNITY: Bel Haven | LOT NUMBER: 59 | CUSTOMER: 5190 Braden Lane, West Chester, OH 45069 - Lot 59

PLANS PREPARED BY HIGHARC

PROJECT SUMMARY	
BUILDING AREA	
CONDITIONED AREA	
FIRST FLOOR SF (OUTSIDE OF FRAME)	2122 SF
TOTAL CONDITIONED AREA :	2122 SF
TOTAL GARAGE AREA :	493 SF
FRONT PORCH AREA :	176 SF
COVERED PATIO AREA :	146 SF
UNCOVERED PATIO AREA :	0 SF

GENERAL NOTES	
ONLY LOCATION SPECIFIC OPTIONS ARE SHOWN ON THESE DRAWINGS. PLEASE REFER TO OPTION SUMMARY AND/OR PURCHASE ORDERS FOR A COMPLETE LISTING OF OPTIONS.	
DESIGN CRITERIA:	
NUMBER OF STORIES: 1	
BUILDING WIDTH: 42'-3"	
BUILDING DEPTH: 79'-7"	
BUILDING HEIGHT: 20'-7 3/4"	
GOVERNMENTAL CODES AND STANDARDS	
HOME TO BE BUILT TO CONFORM TO ALL APPLICABLE LOCAL CODES, PRACTICES AND STANDARDS.	
BUILDING CODE ANALYSIS / DESIGN CRITERIA	
HOME TO BE BUILT TO 2019 RESIDENTIAL CODE OF OHIO STANDARDS	

GRAPHIC SYMBOLS & LEGEND	
	FIRST FLOOR EL. 0'-0"
	ROOF SLOPE
	SD
	SD / CO

SHEET INDEX	
COVER	A-000
SCHEDULES	A-010
GENERAL NOTES	A-020
FOUNDATION PLAN	A-050
FIRST FLOOR PLAN	A-101
ROOF PLAN	A-120
FRONT / BACK ELEVATION	A-200
LEFT / RIGHT ELEVATION	A-201
DETAILS	A-401
DETAILS	A-402
DETAILS	A-403
DETAILS	A-404
PERSPECTIVE VIEWS	A-900
FIRST FLOOR ELECTRICAL PLAN	E-101
SHEAR WALL PLAN	S-100
SHEAR WALL DETAILS	S-101

PROJECT	
PLAN:	BH Promenade Plus D4
ELEV:	Elevation B
LOT:	59
LOT ADDRESS:	
DRAWING TITLE	
COVER	
SHEET NUMBER	
A-000	

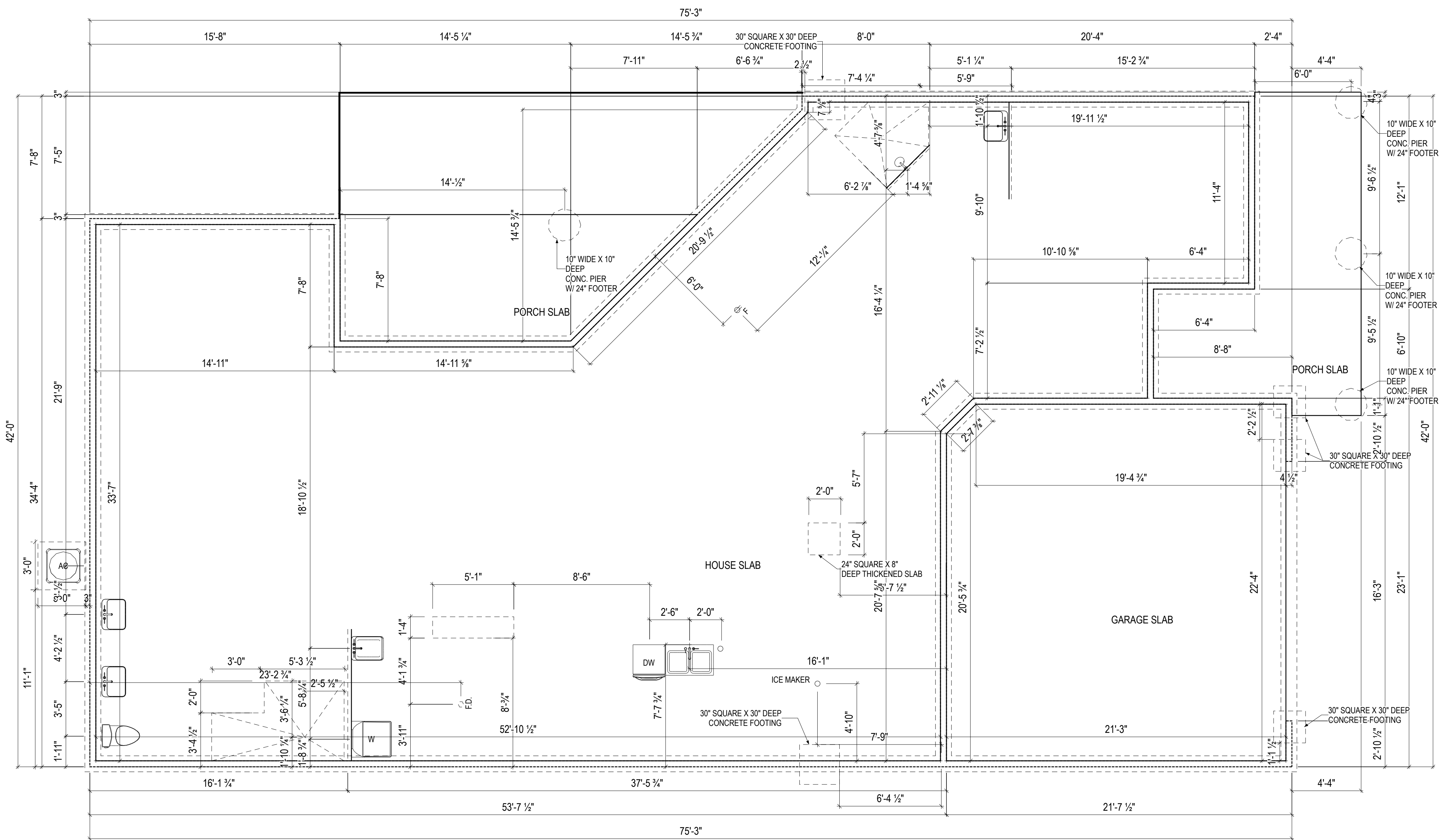

ISSUE	DESCRIPTION	DATE
01	BUILDER SET	6/14/2022

PROJECT
PLAN: BH Promenade Plus D4
 ELEV: Elevation B
 LOT: 59

LOT ADDRESS:

DRAWING TITLE
FOUNDATION PLAN

SHEET NUMBER
A-050

BH 59 - 5190 Braden Lane
1 Story Slab

Ice maker
Humidifier Valve
Irrigation System
Gas Furnace , Heater , Fireplace and Cooktop

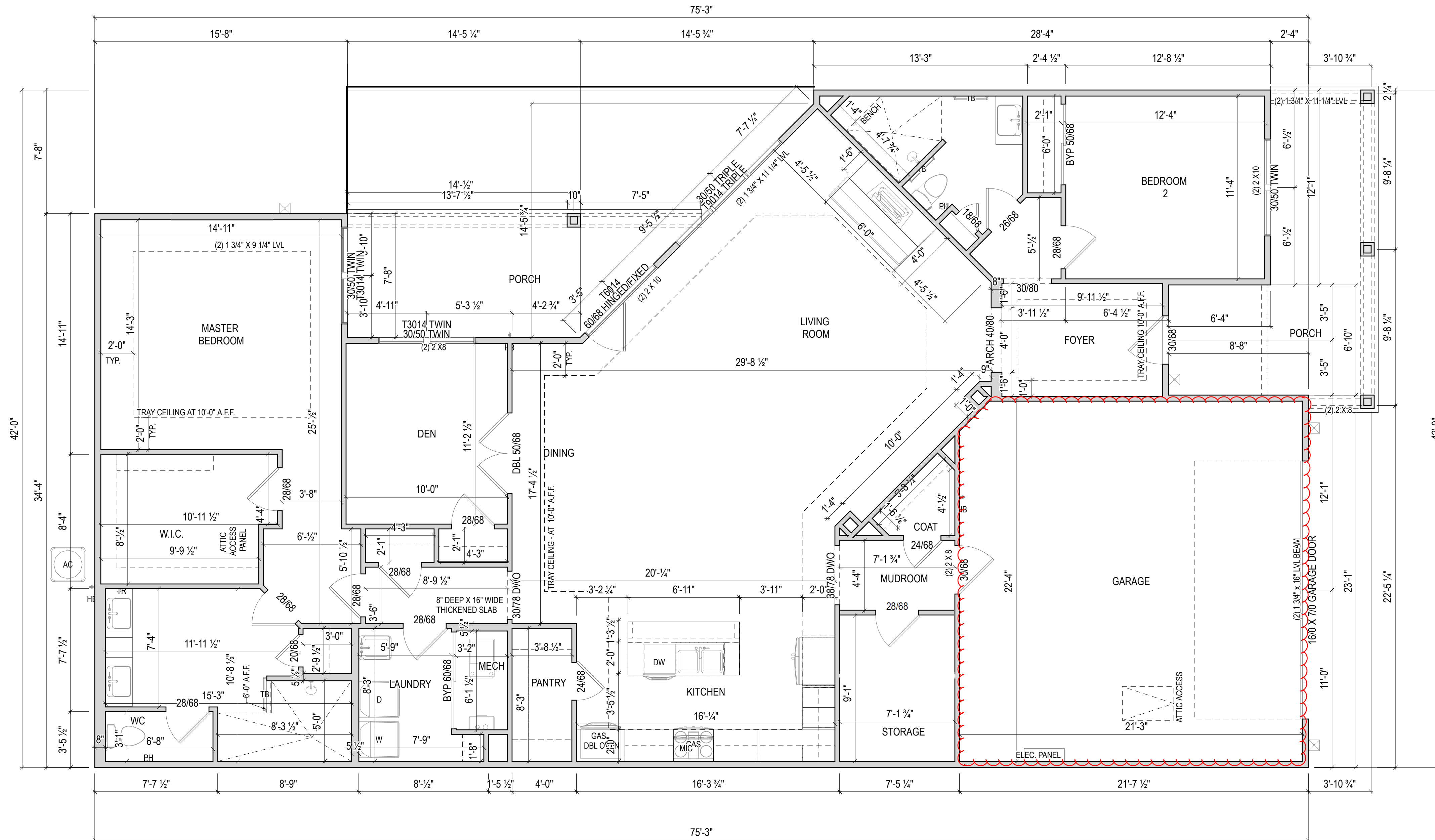

ISSUE	DESCRIPTION	DATE
01	BUILDER SET	6/14/2022

PROJECT
PLAN: BH Promenade Plus D4
ELEV: Elevation B
LOT: 59

LOT ADDRESS:

DRAWING TITLE
FIRST FLOOR PLAN

SHEET NUMBER
A-101

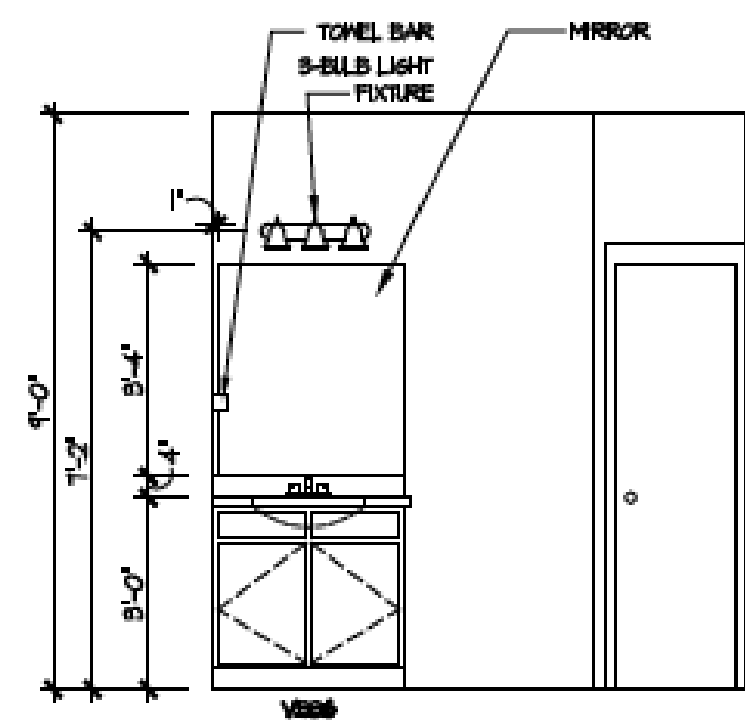

2 Bath 2 - Walk-In Shower
A-402

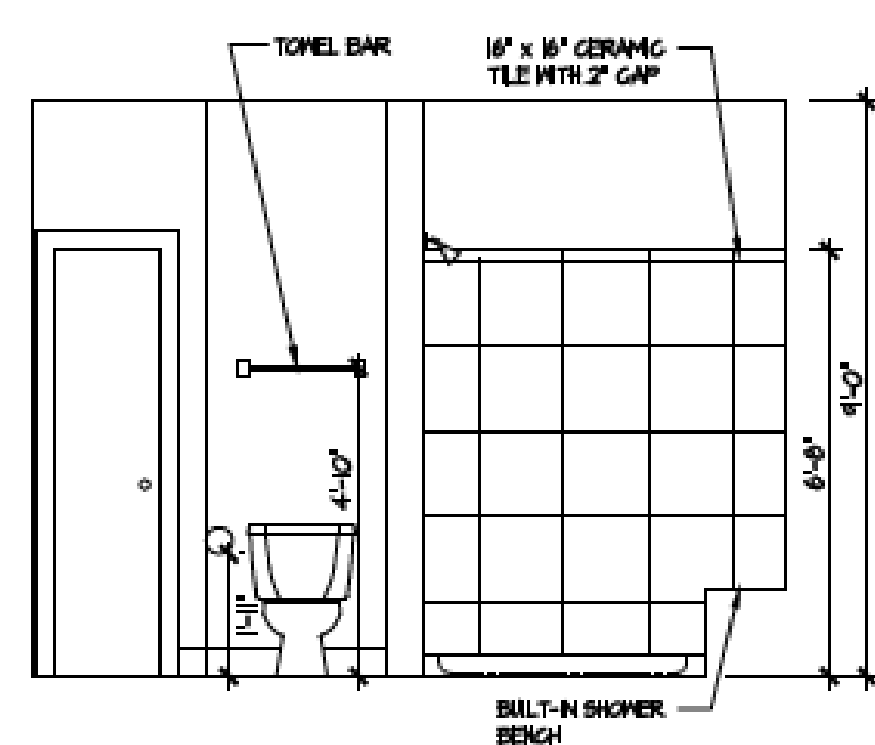

3 Fireplace
A-402

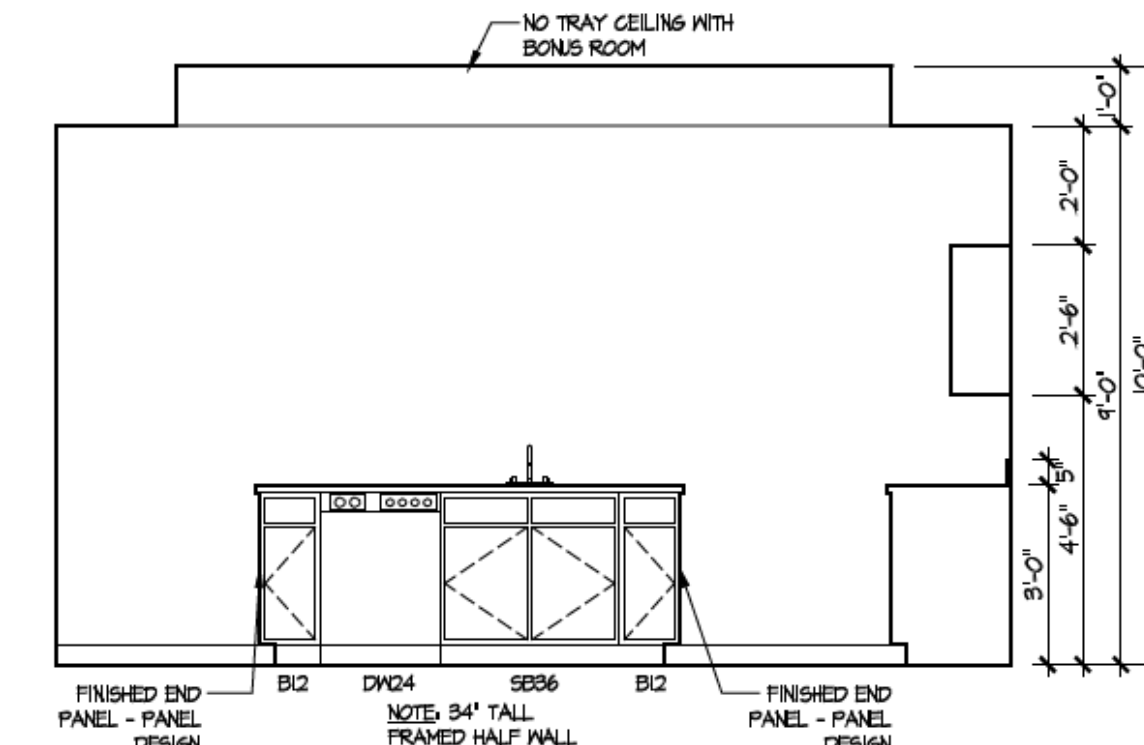

4 Kitchen - Island
A-402

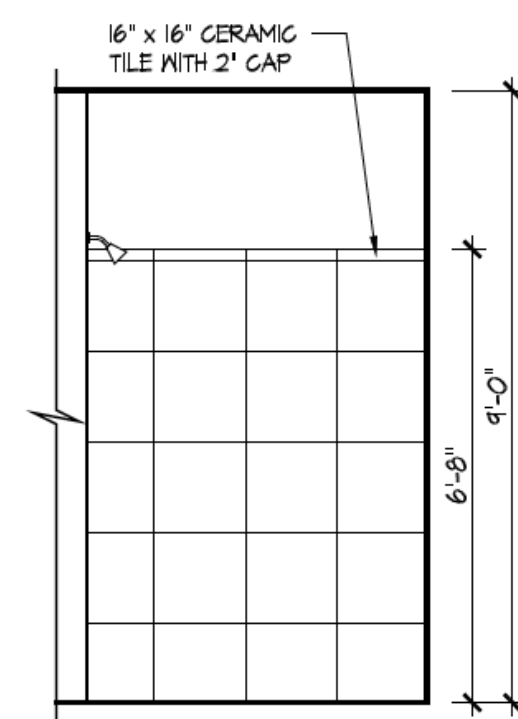

5 Master Bath Shower - Walk-in
A-402

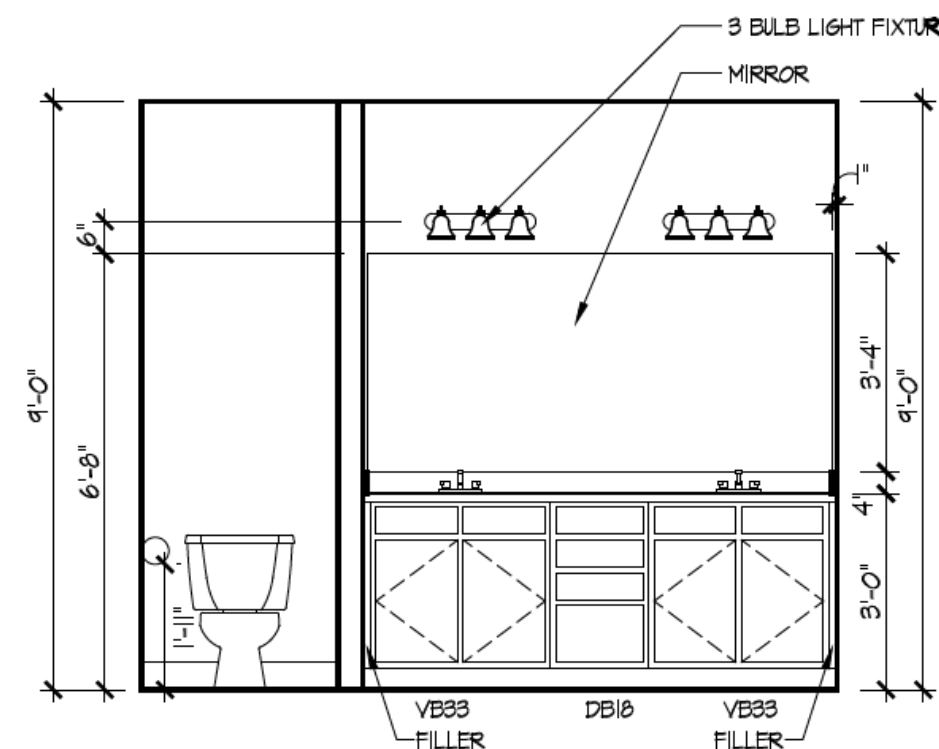

6 Master Bath Vanity
A-402

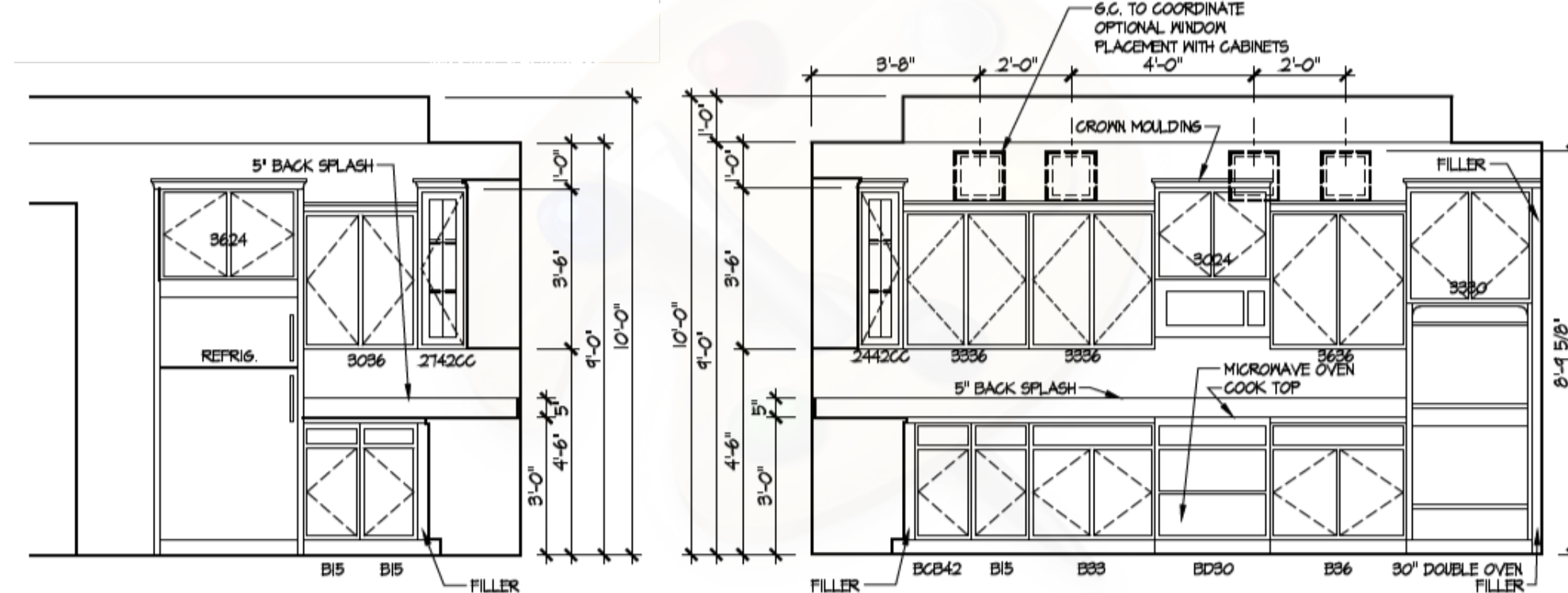

7 Kitchen Deluxe Layout
A-402

ISSUE	DESCRIPTION	DATE
01	BUILDER SET	6/14/2022

PROJECT
PLAN: BH Promenade Plus D4
ELEV: Elevation B
LOT: 59

LOT ADDRESS:

DRAWING TITLE
DETAILS

SHEET NUMBER
A-402