

**SECOND FLOOR PLAN**  
SCALE: 1/4" = 1'-0"

**LEGEND**

- BEARING WALL
- NON BEARING WALL
- INDICATES BEARING FROM POINT-LOAD ABOVE
- JACKS
- BEAM/HEADER
- PAD FOOTING
- STEEL COLUMN
- PORTAL FRAME
- JOIST/TRUSS
- LVL
- ENGINEERING PAGE NUMBER

SEE FC DETAILS FOR FRAMING CONNECTORS

- FLOOR PLAN NOTES**
- ALL HEADERS ARE (2) 2x6 w/ 2x4 WALLS OR (3) 2x6 w/ 2x6 WALLS, UNLESS OTHERWISE NOTED.
  - ALL HEADERS TO HAVE (1) 2x4 OR 2x6 JACK EACH END, UNLESS OTHERWISE NOTED.
  - ALL EXTERIOR WALLS TO BE 4" AND ALL INTERIOR WALLS TO BE 3 1/2", UNLESS OTHERWISE NOTED.
  - HATCHED AREAS INDICATE DROPPED CEILINGS. ALL DROPPED CEILINGS ARE 12" UNLESS OTHERWISE NOTED.
  - SEE "BRACED WALL PANEL DETAIL SHEET" FOR SPECIAL WALL FRAMING LOCATIONS AND HEADER SIZES, IF APPLICABLE.
  - SEE STANDARD DETAIL CATEGORY "IT" SHEET(S) FOR INTERIOR TRIM DETAILS.
  - SEE ARCHITECTURAL DETAIL SHEET "AD" FOR HOUSE SPECIFIC INTERIOR TRIM OPTION TABLE.
  - ALL WINDOWS HAVE 7'-0 1/2" HEADER HEIGHT UNLESS OTHERWISE NOTED.

- GYPSUM NOTES**
- AT GARAGE:  
GYPSUM BOARD AT COMMON WALLS, CEILINGS, BEAM WRAPS AND SUPPORTS PER STANDARD DETAIL FA-1(b) FIRE ASSEMBLIES OR AS REQUIRED BY LOCAL CODE.
- AT STAIRS:  
1/2" GYPSUM BOARD AT UNDERSIDE OF STAIRS AND WALLS IN CLOSET

**SECOND FLOOR JACK SCHEDULE**

IDENTIFIER	DESCRIPTION	OPTIONS	ENG. NUM.	REMARKS
J201	JACK - (2) 2X4 SFF STUD GRADE	ELC, ELL	2001a	
J208	JACK - (2) 2X4 SFF STUD GRADE	ELC, ELL, MAA	2000	
J211	JACK - (3) 2X6 SFF STUD GRADE	ELC	2000	EXTEND TO THRU. TOP PLATE
J212	JACK - (3) 2X6 SFF STUD GRADE	ELC	2000	EXTEND TO THRU. TOP PLATE
J213	JACK - (2) 2X4 SFF STUD GRADE	ELC	2010	

**REMARKS**

REV. NO.	DATE	DESCRIPTION

**MODEL**  
LONDON

**DRAWING TITLE**  
SECOND FLOOR PLAN

**OPTION DESCRIPTION**

**SHEET NO.**  
A-8

**OPTION**  
41

**SET NO.** LDNOO  
**VERSION** 02  
**DRAWN BY** SDTT  
**DATE:** 7/3/15  
**OPTION**

**NVR**  
NVR, Inc.  
Architectural Services  
5285 Washington Blvd  
Frederick, MD 21703

NVR, Inc., owner, expressly reserves its copyright in these plans. These plans are not to be reproduced, changed, copied, or otherwise used in any way without the written consent of NVR, Inc.

C:\NVR\Solves\LONDON\_LDNOO\_02\DCI-CH-MZ13\979128\Sheets\Lot\_Specific\41\_A-B\_FLN2\_LS.dwg 10/17/18 - 3:12 am



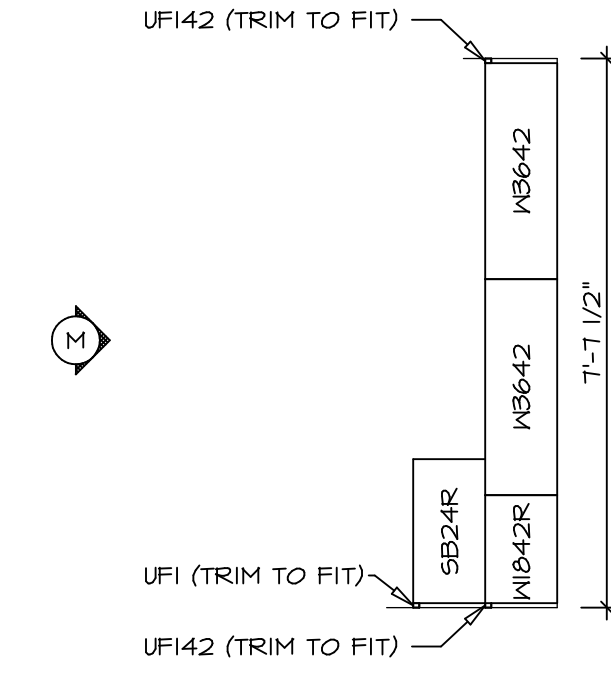

**CABINET PLAN  
KC - 2964**

1  
A-12b SCALE: 3/8" = 1'-0"

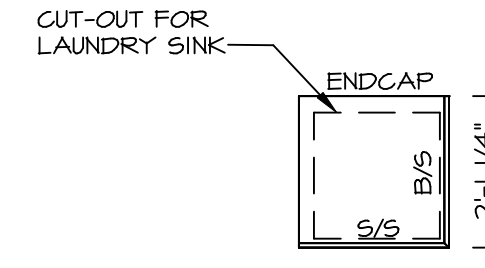

**COUNTERTOP PLAN  
KC - 2964**

2  
A-12b SCALE: 3/8" = 1'-0"

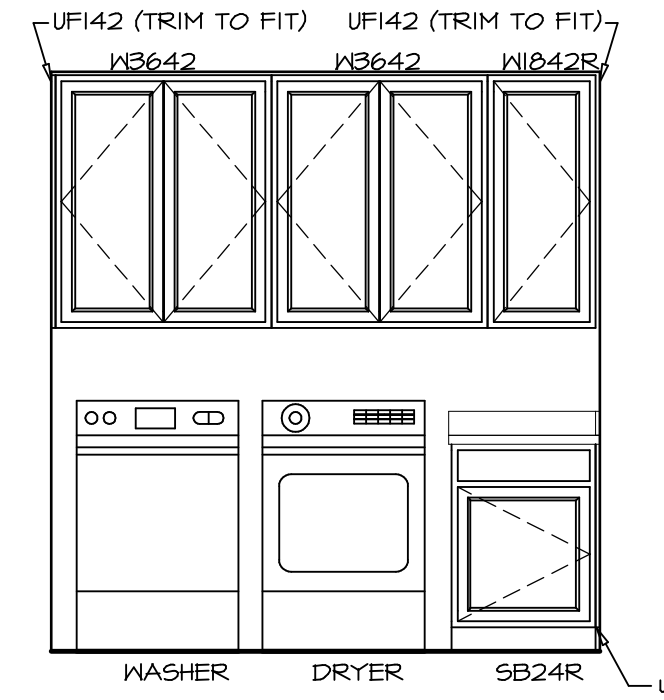

**ELEVATION "M"**

SCALE: 3/8" = 1'-0"

SHEET NO.	MODEL	SET NO.	VERSION	DRAWN BY	DATE	OPTION	REMARKS
A-12b	LONDON KITCHEN PLAN - ADDITIONAL CABINETS	LDN00	02	SDTT	8/6/15		
52							

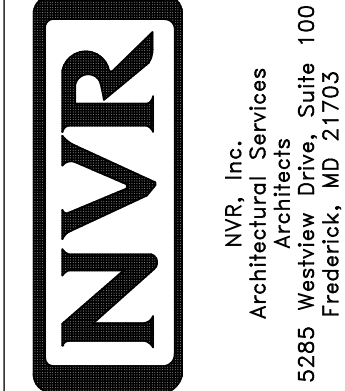

NVR, Inc., owner, expressly reserves its copyright in these plans. These plans are not to be reproduced, changed, copied, or used in any way without the written consent of NVR, Inc.

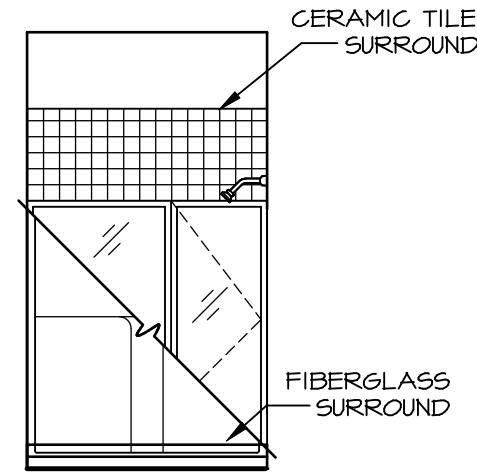

**E** FIRST FLOOR BATH  
SCALE: 1/4" = 1'-0"

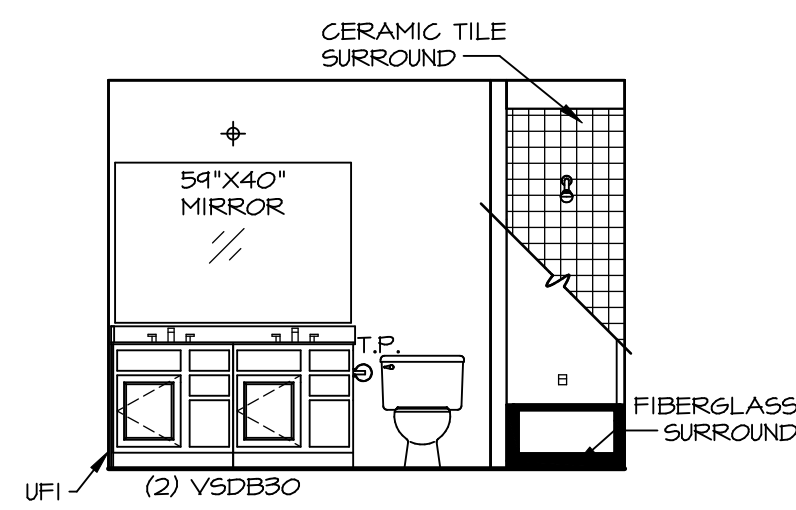

**F** BATH #1  
SCALE: 1/4" = 1'-0"

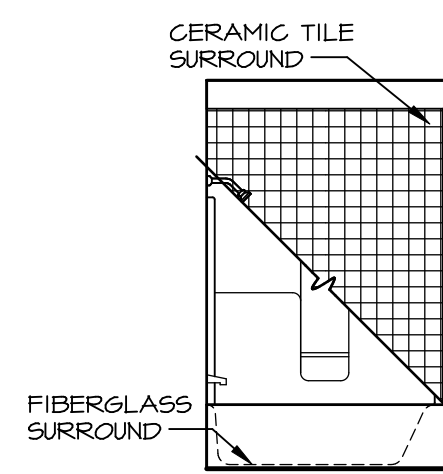

**G** BATH #1  
SCALE: 1/4" = 1'-0"

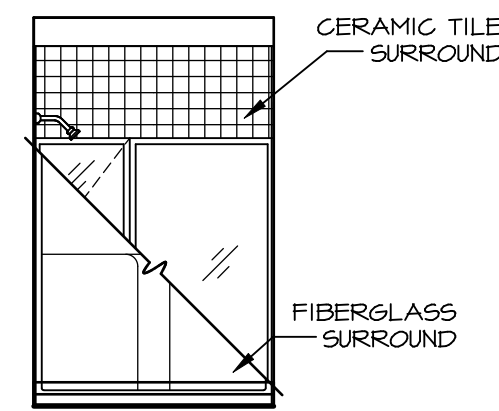

**L** OWNERS BATH  
SCALE: 1/4" = 1'-0"

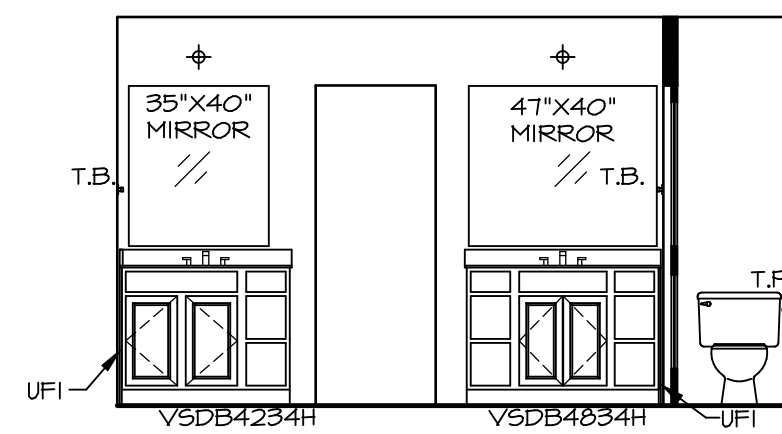

**M** OWNER'S BATH  
SCALE: 1/4" = 1'-0"

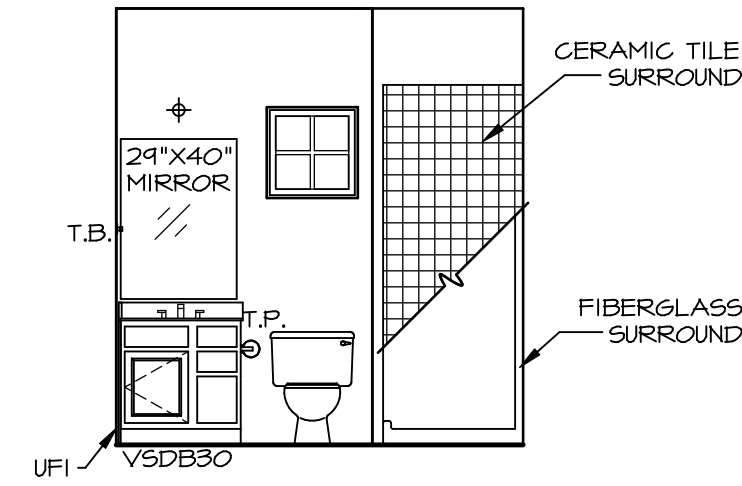

**D** FIRST FLOOR BATH  
SCALE: 1/4" = 1'-0"

**NOTES:**

1. TEMPERED GLASS SHOWER ENCLOSURE WITH SWING DOOR OR OPTIONAL SLIDING DOOR BY DIVISION
2. TUB ACCESS PANELS PROVIDED AS NEEDED, ALL MATERIALS BY DIVISION
3. REFER TO SHEET IT-2 FOR TUB AND SHOWER DETAILS.
4. ALL V5DB24-42 DRAWERS TO BE SET ON RIGHT HAND.
5. BATH ELEVATIONS ARE SHOWN PER PLAN.

SHEET NO.	MODEL	SET NO.	OPTION
A-13	LONDON	LDN00	OPTION
	DRAWING TITLE	VERSION	DATE
	BATH ELEVATIONS	02	7/30/15
		DRAWN BY	SDTT

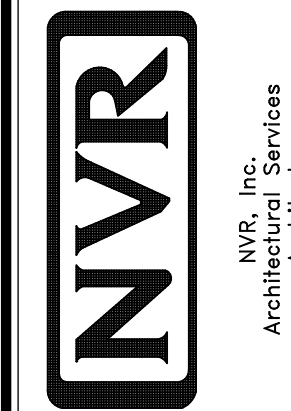

NVR, Inc., owner, expressly reserves its copyright in these plans. These plans are not to be reproduced, changed, copied, or otherwise used in any way without the written consent of NVR, Inc.

REV. NO.	DATE	REMARKS