

# PLOT PLAN

## LOT 4691 (7,500 SF) 0.1722 ACRES

### CENTENNIAL RUN, SECTION THREE, BLOCK "A"

### SECTION 31, TOWN 2, RANGE 4

### CITY OF TRENTON, BUTLER COUNTY, OHIO

### FOR: CRISTO HOMES

BROWN RESIDENCE  
323 GOVERNORS AVENUE

TOPOGRAPHY FROM APEX FIELD SURVEY, DATED MAY 1, 2018, AND MAY NOT REFLECT CURRENT CONDITIONS.

MS=662.18

SETBACKS  
FRONT=35'  
REAR=40'  
SIDE=6' MIN/15' TOTAL

**QUANTITIES**

TOTAL LOT AREA	7,500	sq. ft.
CITY WALK	220	sq. ft.
HOUSE WALK	49	sq. ft.
DRIVE	656	sq. ft.
APRON	93	sq. ft.
PATIO AND PORCHES	33	sq. ft.
DECK	-	sq. ft.
SEEDING AREA	5,839	sq. ft.

**INFORMATION FROM CONSTRUCTION DRAWINGS.**

CONTRACTOR IS TO VERIFY LOCATION AND DEPTH OF WATER AND UTILITY SERVICES BEFORE CONSTRUCTION.

ALL ELEVATIONS ARE EXISTING UNLESS SPECIFIED WITH AN "E" FOR EXISTING OR A "P" FOR PROPOSED.

UNLESS F.F.E., M.O.E. OR M.B.E. ARE FIELD VERIFIED BY AN ENGINEERING FIRM, CONTRACTOR TAKES FULL RESPONSIBILITY FOR THE FINISH FLOOR ELEVATION.

A STANDARD FORMULA WAS USED TO DETERMINE FINISH FLOOR GRADE. FINAL FINISH FLOOR ELEVATION IS CONTRACTOR'S RESPONSIBILITY.

PRIOR TO CONSTRUCTION, A GEOTECHNICAL REPORT SHALL BE OBTAINED BY THE BUILDER. APEX ASSUMES NO RESPONSIBILITY FOR SOIL CONDITIONS.

BUILDER SHALL PROVIDE POSITIVE DRAINAGE AROUND AND AWAY FROM HOUSES.

APEX ENGINEERING & SURVEYING INC. ADVISES AGAINST HOLDING THE MINIMUM REQUIRED DISTANCE ON ANY AND ALL SETBACKS, FRONT, REAR, AND SIDES. THE BUILDER ASSUMES ALL RESPONSIBILITIES FOR ANY BUILDING ENCROACHMENTS THAT MAY OCCUR.

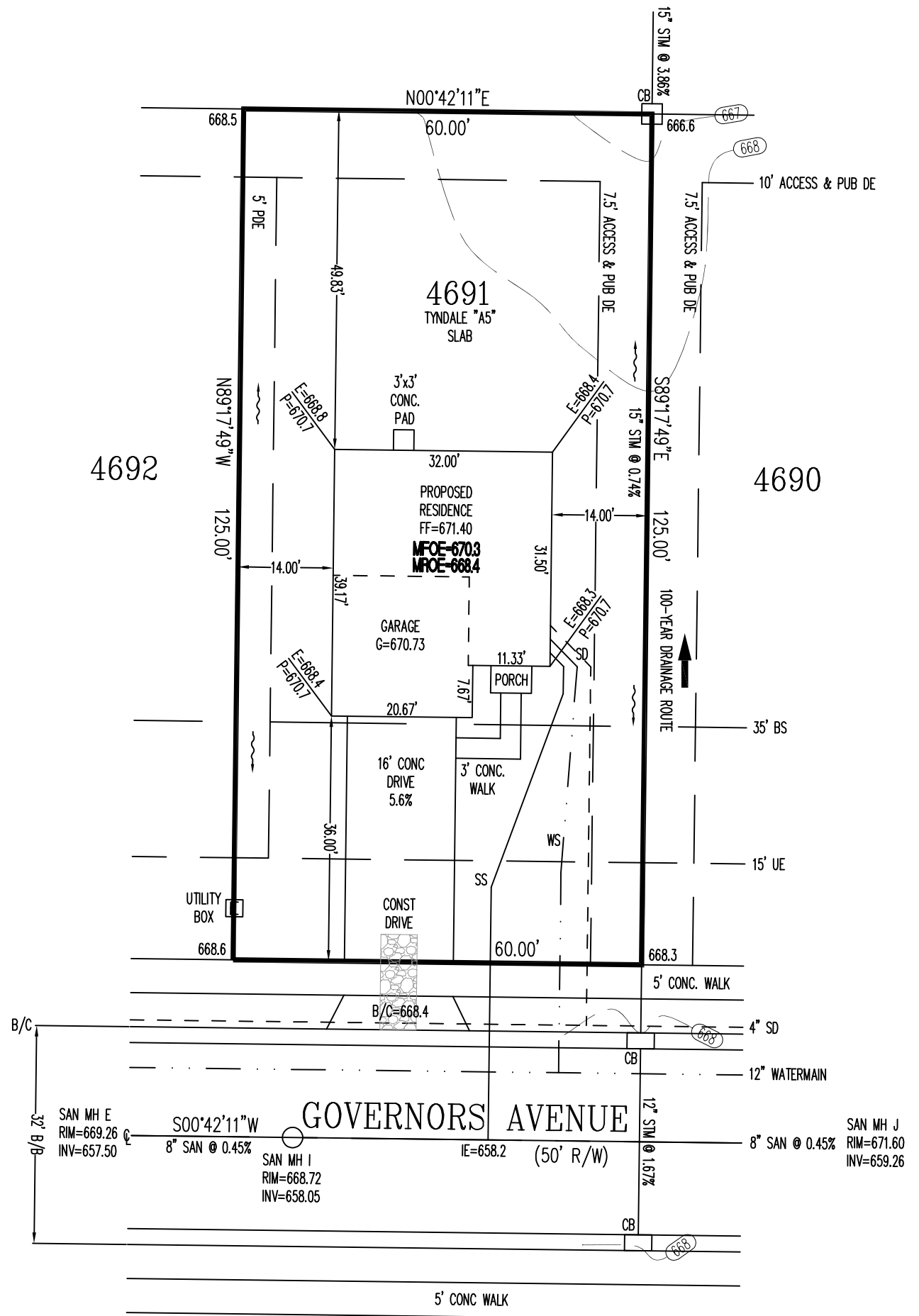

M.F.O.E. = 670.3'  
M.R.O.E. = 668.4'

SCALE: 1"=20'  
DATE: 2/28/2019  
DRAWN: REW  
DESIGNED: -  
CHECKED: KRC

**APEX**  
ENGINEERING & SURVEYING, INC.  
1068 N. UNIVERSITY BLVD MIDDLETOWN, OHIO 45042  
PH.-(513) 424-5202 OR (513) 932-8991 FAX - (513) 424-6202

REVISIONS:	
1.	
2.	
3.	
4.	
PROJECT: CENTENNIALRUN	SHEET 1 OF 1
DRAWING: 190403PA	

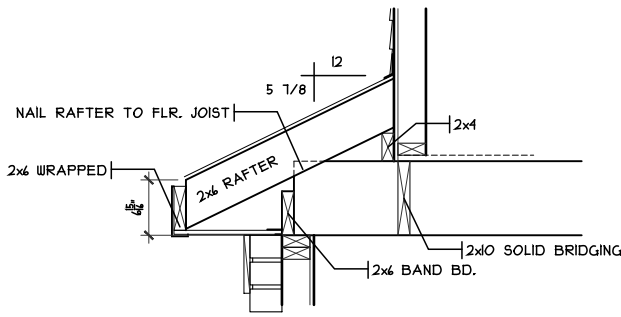

**GARAGE DETAIL**  
SCALE: 1/2" = 1'-0"

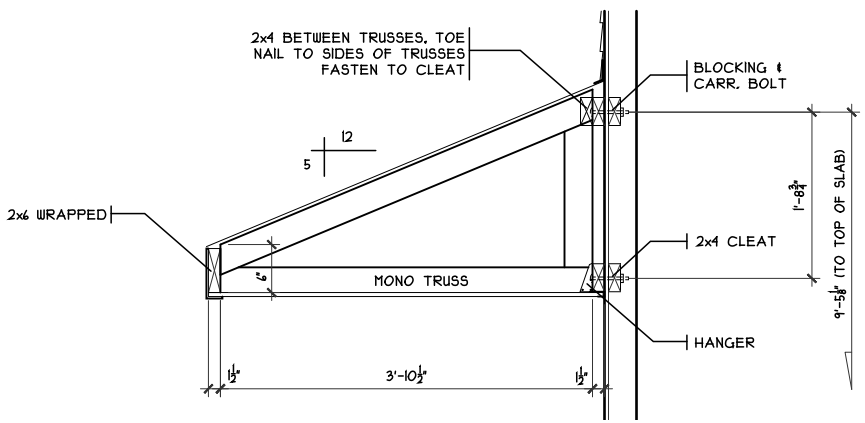
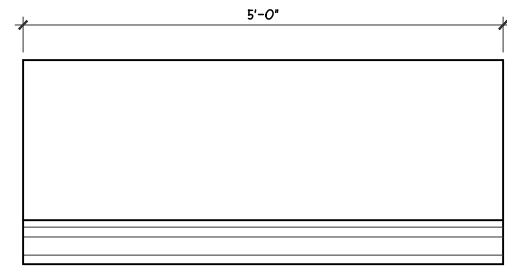

**PORCH DETAIL**  
SCALE: 1/2" = 1'-0" ELEVATION A



**REAR ELEVATION**  
SCALE: 1/8" = 1'-0"

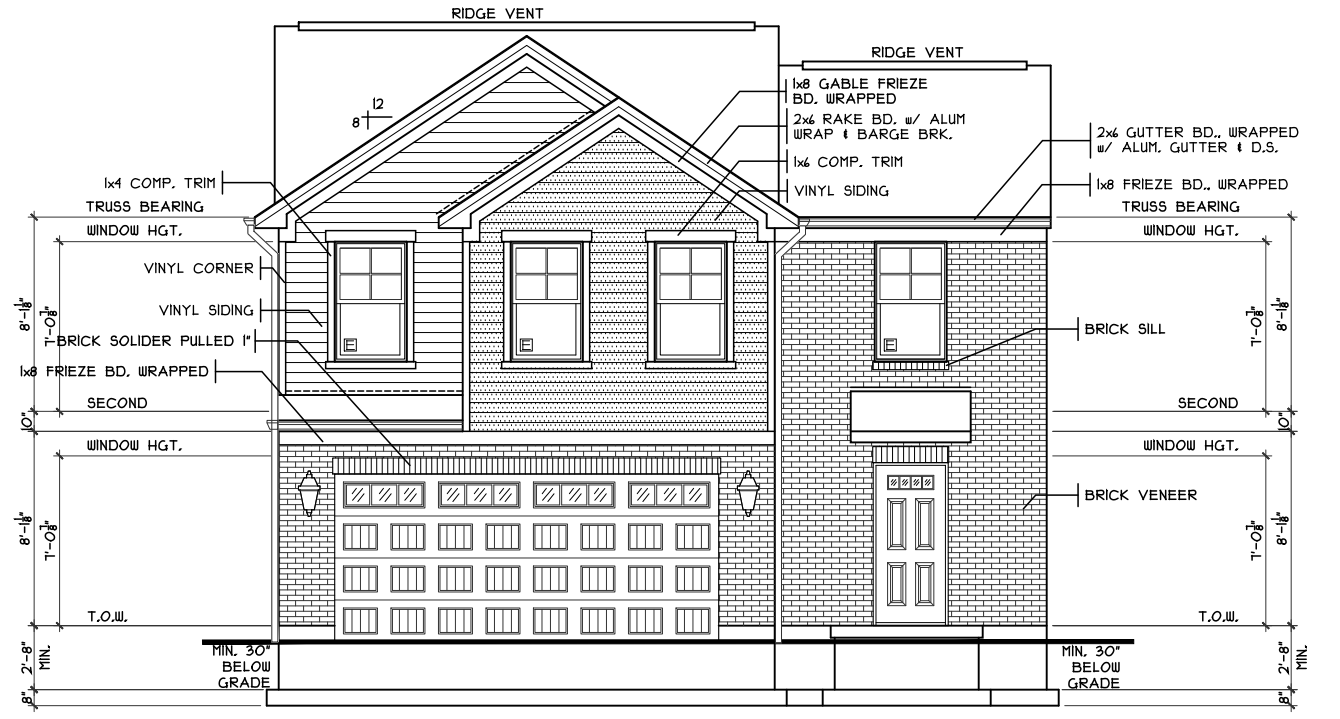

**FRONT ELEVATION**  
SCALE: 1/8" = 1'-0" ELEVATION A5

SHEET INDEX	
SHT#	DESCRIPTION
A1	Front and Rear Elevations (A5)
A1a	Left and Right Elevations (A5)
A2	Foundation Plan
A3	First Floor Plan
A4	Second Floor Plan
A5	Typical Wall Sections/Stair Section
A6	Typical Framing Details (Aluminum)
G1	General Notes
E1	Electrical Plan
S1	Second Floor Joist Layout / Roof Plan

NOTE:  
PLANS PRINTED ON 24x36 SHEETS TO BE SCALABLE AT FULL SCALE. 1/4" = 1'-0"  
PLANS PRINTED ON 11x17 SHEETS TO BE SCALABLE AT HALF SCALE. 1/8" = 1'-0"

Issue Dates
Review

Tyndale Slab - A5 - Vinyl W/Brick  
Cristo Homes reserves all property rights in these plans. These plans are not to be reproduced, changed, or copied in any manner. They are not to be given to a third party, either in full or in part, without first receiving written permission from Cristo Homes. In the event these plans are used by a third party, Cristo Homes shall be held harmless.

CR-4691  
Proposed Residence:  
Brown Residence  
CR - Centennial Run  
323 Governors Avenue Lot-4691  
Trenton  
Butler County

2S1866B4 PLAN INFO	
4	BDRMS
2.5	BATHS
2	CAR GARAGE
8'	1ST FLR. CLG.
SQUARE FOOTAGE	
TOTAL	1844
MAIN	143
UPPER	123
LOWER (SLAB)	665
GARAGE (SLAB)	386

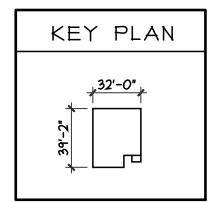

**OPTIONS**

Elevation A5  
Plan: Tyndale Slab  
Date: 2.15.2019  
Drawn: MA  
Scale: As Noted  
Revised:  
Sheet: 1 of 10

**A1**



7594-A Tylers Place Blvd.  
West Chester, OH 45069  
513.755.0570 www.cristohomes.com

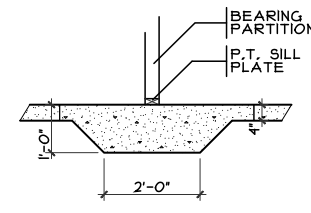

**THICKENED SLAB**  
SCALE: 1/4" = 1'-0"

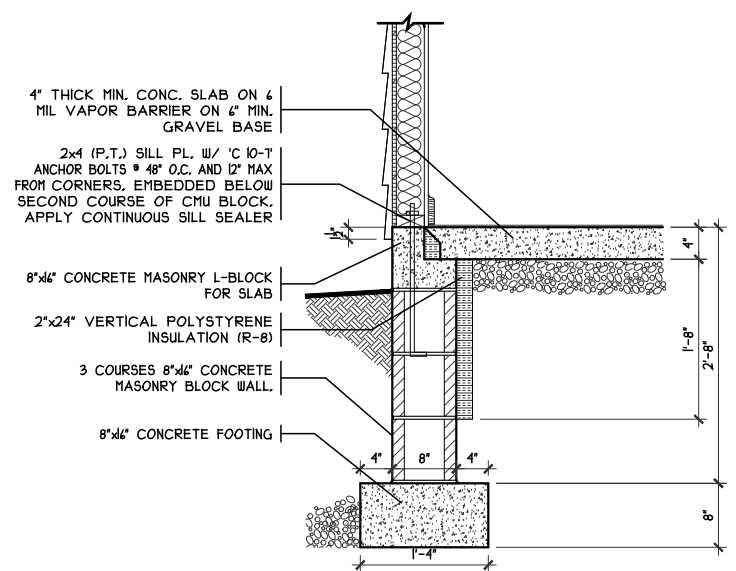

**SOG DETAIL**  
SCALE: 1/8" = 1'-0"

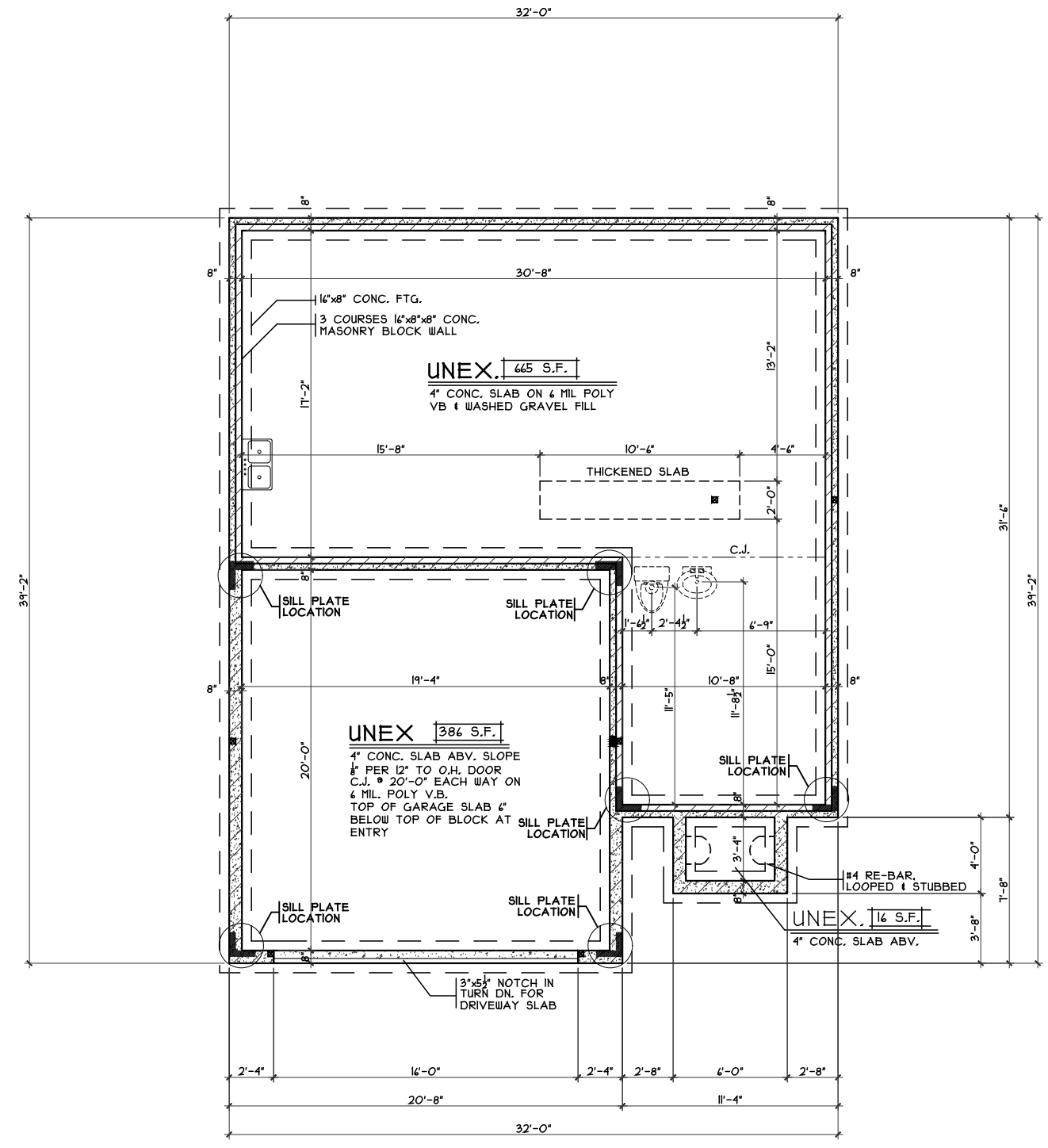

**FOUNDATION PLAN**  
SCALE: 1/8" = 1'-0"

OPTIONS

Foundation Plan  
Plan: Tyndale Slab  
Date: 2/15/2019  
Drawn: MA  
Scale: As Noted  
Revised:  
Sheet: 3 of 10



7594-A Tylers Place Blvd.  
West Chester, OH 45069  
513.755.0570 www.cristohomes.com

CR-4691  
Proposed Residence:  
Brown Residence  
CR- Centennial Run  
323 Governors Avenue Lot-4691

Trenton  
Butler County

Tyndale Slab - A5 - Vinyl W/Brick  
Cristo Homes reserves all property rights in these plans. These plans are not to be reproduced, changed, or copied in any manner. They are not to be given to a third party, either in full or in part, without first receiving written permission from Cristo Homes. In the event these plans are used by a third party, Cristo Homes shall be held harmless.

Review	Issue Dates

A2

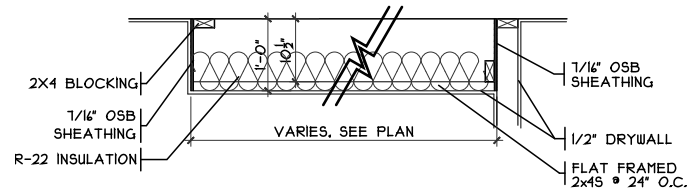

**DROP CLG. DETAIL**  
SCALE: 1/8" = 1'-0"  
GARAGE

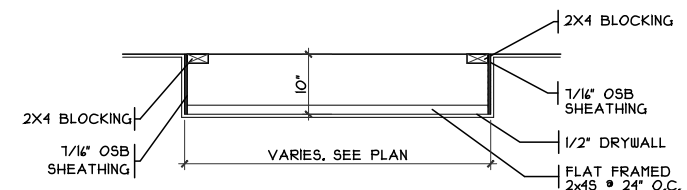

**DROP CLG. DETAIL**  
SCALE: 1/8" = 1'-0"

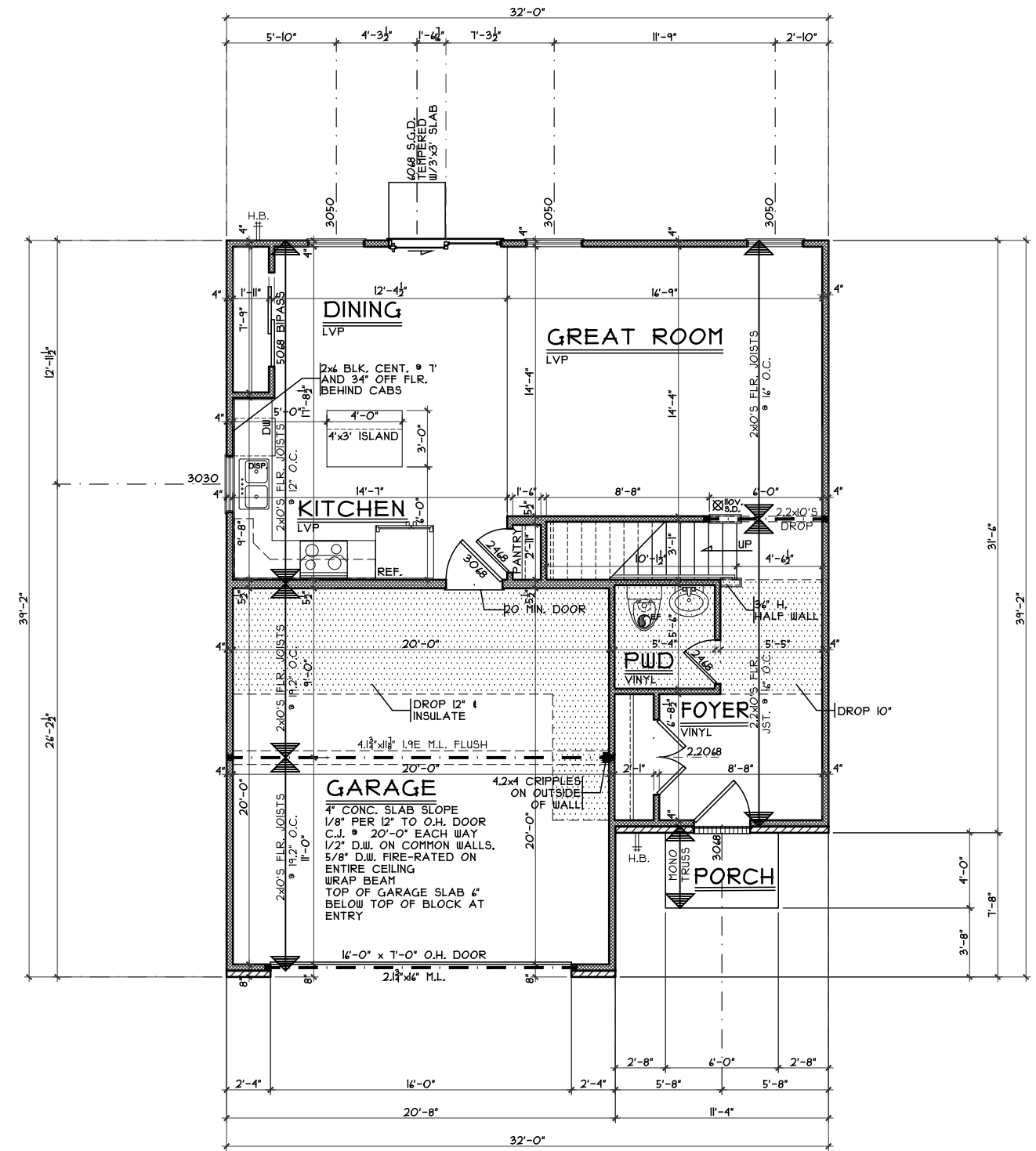

OPTIONS

First Floor Plan  
Plan: Tyndale Slab  
Date: 2.15.2019  
Drawn: MA  
Scale: As Noted  
Revised:  
Sheet: 4 of 10



Proposed Residence:  
**Brown Residence**  
CR - Centennial Run  
323 Governors Avenue Lot-4691

CR-4691

Trenton  
Butler County

Tyndale Slab - A5 - Vinyl W/Brick

Review	Issue Dates

Cristo Homes reserves all property rights in these plans. These plans are not to be reproduced, changed, or copied in any manner. They are not to be given to a third party, either in full or in part, without first receiving written permission from Cristo Homes. In the event these plans are used by a third party, Cristo Homes shall be held harmless.

**A3**

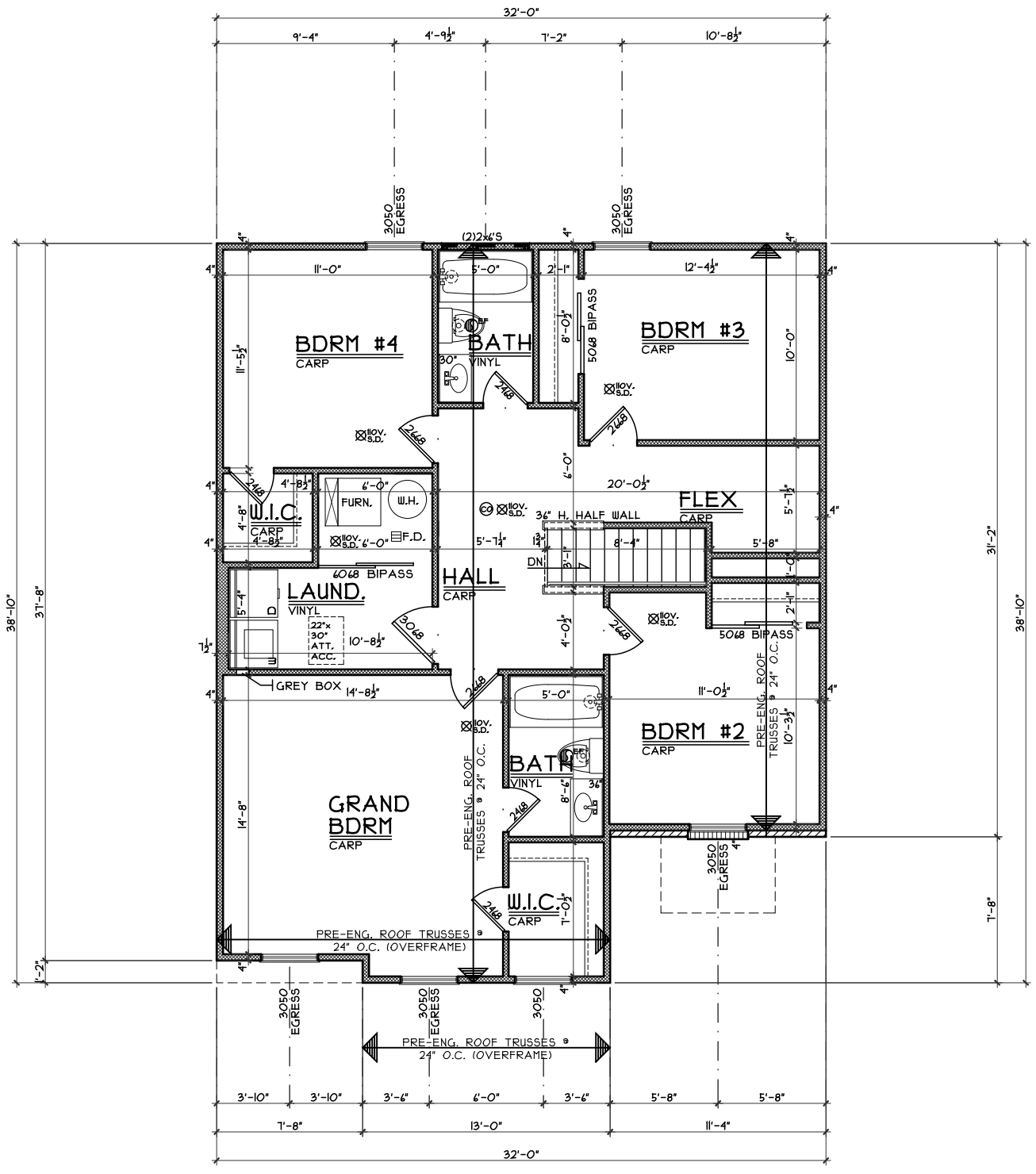

**SECOND FLOOR PLAN**  
SCALE: 1/8" = 1'-0" 1121 S.F

OPTIONS

Second Floor Plan

Plan: Tyndale Slab  
Date : 2.15.2019  
Drawn: MA  
Scale : As Noted  
Revised:  
Sheet : 5 of 10



7594-A Tylers Place Blvd.  
West Chester, OH 45069  
513.755.0570 www.cristohomes.com

CR-4691

Proposed Residence:  
Brown Residence  
CR- Centennial Run  
323 Governors Avenue Lot-4691

Trenton  
Butler County

Tyndale Slab - A5 - Vinyl W/Brick

Cristo Homes reserves all property rights in these plans. These plans are not to be reproduced, changed, or copied in any manner. They are not to be given to a third party, either in full or in part, without first receiving written permission from Cristo Homes. In the event these plans are used by a third party, Cristo Homes shall be held harmless.

Issue Dates

Review	Issue Dates

A4